

## **“Conley’s Bridge”**

Spanning the accessibility Gap



Persons wanting or needing a portable and adjustable work stand for jobs such as reading, writing, crafts or using a laptop computer are limited as to what is available. Typically used are over bed hospital type stands, “pillow” desks, or slant boards. These devices are limited as to positioning. The over bed table is limited as to the angle setting that may be required for user access and storage when not in use becomes a problem. Pillow desks are lacking in the tilting feature as may be required and are quite large and difficult to store. Slant boards are for smooth surface usage and offer angle adjustment, but not height adjustment. Slant boards are unstable when used on a person’s lap.

Our work stand, “Conley’s Bridge”, is adjustable for height and angle, is lightweight and easily collapses for storage. The straight leg design provides a more stable work surface that is supported on same surface as the user. Our stand will be an assistive work positioning aid for persons effected with, but not limited to, Arthritis, Stroke, Carpal Tunnel, Cerebral Palsy, Multiple Sclerosis, or Reduced Vision.

Our patented “Leg Adjustment Lock”, detail #134 for less than 1/4 turn for locking of adjustments will simplify set-up and adjustments for all users and not just the challenged user. Making it a truly universal design. Additional leg lengths and shapes will be developed as demand may dictate.

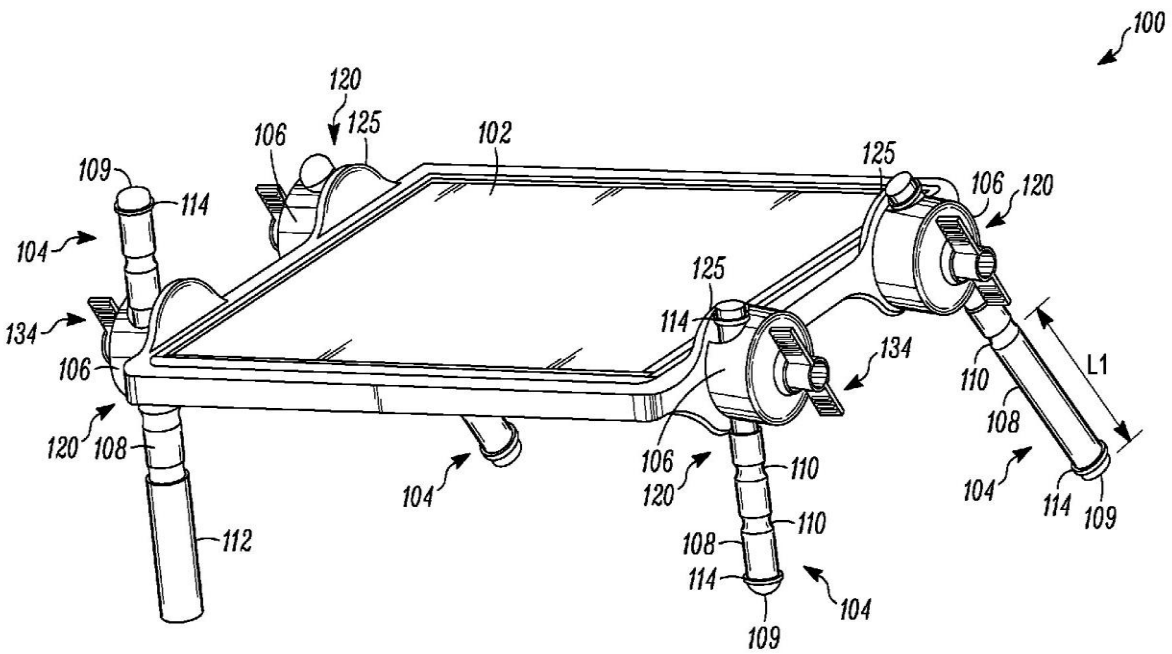

**Patent Drawing**

**Market Target**

Targeted for marketing will be computer users in general and specifically the 52 million disabled persons in the U.S.A. Additionally 352.4 million computer units will be sold in 2010, and 409 million units is projected for 2011.

It is reported that musculoskeletal disorders of the low back and upper extremities are an important and costly national health problem. Musculoskeletal disorders account for nearly 70 million physician office visits in the United States annually and an estimated 130 million total health care encounters including outpatient, hospital, and emergency room visits. In 1999, nearly 1 million people took time away from work to treat and recover from work-related musculoskeletal pain or impairment of function in the low back or upper extremities. Conservative estimates of the economic burden imposed, as measured by compensation costs, lost wages, and lost productivity, are between \$45 and \$54 billion annually.

Persons with limitation such as but not limited to stroke, arthritis, carpal tunnel, vision limitations, or musculoskeletal disorders will find the stand a useful aid for such tasks as reading or writing, laptop computer, arts & crafts, or video gaming.

Application to the FDA for approval as DME, Durable Medical Equipment, will enable sales by prescription as many be issued by a doctor for any use seen appropriate.

## Usage

Various leg lengths and shapes and portability will permit usage in places ranging from an easy chair or recliner to bed or outside. Usage for travel can be developed with correct leg length configuration.



## Optional Size & Leg Design

The stand will be used for, but not limited to, eating, keyboarding, laptop computer, arts & crafts, video gaming, reading / writing, or other task that may require the unique features offered by our product.

A market survey conducted with 56 potential users and groups produced three suggestions that will be incorporated into the final design.

1. Retainer lip preventing roll-off on all sides.
2. Flange preventing support legs from protruding above the work surface.
3. Raised surface for wrist support.

Five clip on accessories have been designed to assist the user.

1. Paper or book clamp
2. Wrist rest
3. Pencil tray
4. Marker Holder
5. Cup Holder

A meeting with the director of assistive devices, Dr. Stephen Reger, at the Cleveland Clinic resulted with the doctor commenting that the device is a "universal design" that will be used by all and not limited to the disabled as was the initial target market



### **Optional Usage**

Our patented "Leg Adjustment Lock" will simplify set-up and adjustments for all users and not just the challenged. Making it a truly universal design. Additional leg lengths and shapes will be developed as demand may dictate.

Potential users will include hospitals, rehab centers, special education, retirement centers, and all computer users.

During development, research showed there is no similar device for persons requiring or desiring a portable and adjustable work stand with the unique "turn to lock" patented feature of our product. Our "turn to lock" feature removes the question of correct locking force. Typically people requiring a raised and portable work stand use a pillow or like device for access to their work and reduce heat as with a laptop computer. This results in an unstable work surface. Our unique design allows for usage of work such as a laptop computer in most places as may be required. To be considered is an easy chair, bed, or outside. Any place requiring other than a flat support area.

Contact information:

440-372-0704 (A.M. only, (please)

Email [jzn44qt@aol.com](mailto:jzn44qt@aol.com)

Thank you for consideration,  
Roy P. Conley  
Inventor